

# Aberrometer

INSTRUCTIONS FOR USE

# Osiris



COSTRUZIONE STRUMENTI OFTALMICI

Via degli Stagnacci 12/E | 50018 Scandicci (FI) | ITALY  
Phone: +39 055 722191 | Fax: +39 055 721557

[cso@csitalia.it](mailto:cso@csitalia.it) | [www.csitalia.it](http://www.csitalia.it)

OSIRISIFUENGCSO0207052025





1	INTRODUCTION .....	5
1.1	SYMBOLS .....	5
1.1.1	<i>Device symbols</i> .....	6
1.2	GENERAL WARNINGS .....	6
1.3	REFERENCE REGULATIONS.....	7
1.3.1	<i>EU Directives</i> .....	7
1.3.2	<i>Technical standards</i> .....	7
1.3.3	<i>Quality management system standards</i> .....	7
1.4	WARRANTY .....	8
1.5	MANUFACTURER IDENTIFICATION .....	9
2	SAFETY.....	10
2.1	SAFETY WARNINGS .....	10
2.2	DEVICE IDENTIFICATION .....	12
2.2.1	<i>Registration data in the List of Medical Devices</i> .....	12
2.2.2	<i>Device data plate</i> .....	12
2.2.3	<i>Power supply unit data plate</i> .....	13
2.3	INTENDED USE.....	13
2.4	MEDICAL DEVICE CLASSIFICATION .....	15
2.5	ELECTROMEDICAL DEVICE CLASSIFICATION .....	16
2.6	ENVIRONMENTAL CONDITIONS .....	16
2.7	DISPOSAL AT THE END OF THE USEFUL LIFE .....	17
2.8	MANUFACTURER DECLARATIONS.....	19
2.8.1	<i>Electromagnetic compatibility</i> .....	19
3	DEVICE DESCRIPTION .....	24
3.1	SUPPLY DESCRIPTION .....	24
3.1.1	<i>Osiris device</i> .....	26
3.1.2	<i>Power supply unit</i> .....	27
3.1.3	<i>Chin rest</i> .....	28
3.1.4	<i>Ophthalmic table</i> .....	29
3.1.5	<i>Personal Computer</i> .....	29
3.2	TECHNICAL DATA .....	31
4	DEVICE USE .....	32
4.1	HOW TO INSTALL THE DEVICE .....	32
4.2	HOW TO CONNECT THE DEVICE.....	37
4.3	HOW TO ARRANGE THE ELECTRIC CABLES .....	38
4.4	HOW TO TURN ON THE DEVICE .....	39
4.4.1	<i>How to test the calibration</i> .....	39
4.4.2	<i>How to create a new patient</i> .....	41
4.4.3	<i>How to create a new examination</i> .....	41
4.5	HOW TO ADJUST THE CHIN CUP .....	41
4.6	HOW TO ACQUIRE AN IMAGE .....	44
4.7	HOW TO REPLACE CHIN CUP PAPERS .....	46
4.8	HOW TO TURN OFF THE DEVICE .....	47

---

5	ORDINARY MAINTENANCE .....	48
5.1	SAFETY WARNINGS .....	48
5.2	ELECTRICAL SAFETY CHECK .....	48
5.3	CLEANING AND DISINFECTION .....	49
5.3.1	<i>Recommended products for cleaning and disinfection</i> .....	50
5.3.2	<i>Classification of the criticality of the device</i> .....	51
5.3.3	<i>Device cleaning</i> .....	51
5.3.4	<i>Cleaning the applied parts</i> .....	52
5.3.5	<i>Cleaning the optical components</i> .....	52
5.4	DEVICE EXCURSION CHECK .....	52
5.5	DEVICE CALIBRATION TEST .....	53
5.6	LIST OF SPARE PARTS AND ACCESSORIES .....	53
5.7	TROUBLESHOOTING .....	54

# 1 INTRODUCTION

The device is the result of extensive research, conducted with experts to ensure the product's technical innovation, quality and design. The device can be used easily thanks to the guided manual acquisition and the electronic control of all its functions.

## 1.1 SYMBOLS

The following symbols may be displayed in the instructions for use, on the package or on the device:

Symbol	Meaning
	Caution
	Danger of electric shock
	Read the instructions for use
	General obligation
	Note. Useful information for the user
	General prohibition sign
	Manufacturer
	CE Marking (Directive 93/42/EEC) Identification number of the notified body (IMQ)



Medical device



Waste disposal in compliance with Directives 2012/19/EU (WEEE) and 2011/65/EU (RoHS II)

### 1.1.1 DEVICE SYMBOLS

Symbol

Meaning



Type B applied part

## 1.2 GENERAL WARNINGS

THESE INSTRUCTIONS FOR USE REFER TO THE OSIRIS DEVICE (HEREINAFTER “DEVICE”).

THE ORIGINAL TEXT IS IN ITALIAN.



Before using the device or after a long period of non-use, carefully read these instructions for use. Follow the directions provided in the instructions for use and on the device.



Always keep these instructions for use in an accessible and nearby place. If you decide to sell this device to a new user, remember to include these instructions, complete and readable.



Keep the original box and packaging, as the free-of-charge support service does not cover damage resulting from inadequate packaging of the device when sent back to an authorised Service Centre.



Check for potential damage to the device caused by transport/storage prior to its use.



It is forbidden to reproduce, in full or in part, texts or images contained in these instructions for use without the written authorization of the Manufacturer.



The Manufacturer reserves the right to modify the contents of the instructions for use without prior notice.

## **1.3 REFERENCE REGULATIONS**

### **1.3.1 EU DIRECTIVES**

- Directive 93/42/EEC and subsequent modifications and additions concerning medical devices
- Regulation (EU) 2017/745 of the European Parliament and Council of 5 April 2017 on medical devices (to the extent applicable)
- Directive 2012/19/EU on waste of electric and electronic equipment (WEEE)

### **1.3.2 TECHNICAL STANDARDS**

- IEC 60601-1 - "Medical electrical equipment - Part 1: General requirements for basic safety and essential performance"
- IEC 60601-1-2 - "Collateral Standard: Electromagnetic disturbances - Requirements and tests"
- UNI EN ISO 15004-1 - Ophthalmic Instruments. Fundamental requirements and test methods - Part 1: General requirements applicable to all ophthalmic devices
- UNI EN ISO 15004-2 - Ophthalmic Instruments. Fundamental requirements and test methods - Part 2: Light hazard protection.
- UNI CEI EN ISO 14971 - Medical devices. Application of risk management to medical devices.
- UNI EN ISO 19980 - Ophthalmic instruments - Corneal topographers

### **1.3.3 QUALITY MANAGEMENT SYSTEM STANDARDS**

- UNI CEI EN ISO 13485 - Medical devices. Quality management systems - Requirements for regulatory purposes".

## 1.4 WARRANTY

The Manufacturer is responsible for the compliance of the device with EU Directive 93/42/EEC as amended by 2007/47/EC for:

- performance
- safety and reliability
- CE marking

The Manufacturer rejects all responsibility for:

- installation and start-up that is not carried out in compliance with the directions and precautions reported in the instructions for use
- use that fails to comply with the instructions for use or precautions reported in the instructions for use
- use of accessories or spare parts not provided or suggested by the Manufacturer
- repairs and safety checks not carried out by expert, qualified and trained personnel authorised by the Manufacturer
- failure of the electrical system of the premises where the device is installed to comply with the technical standards, laws and regulations in force in the country where the device is installed
- direct or indirect consequences or damage to objects or persons caused by the misuse of the device or erroneous clinical analysis originating from its use

This device is covered by a limited warranty granted by your authorised dealer for the period required by law. The warranty covers the replacement by the Manufacturer or an authorised Service Centre of components and materials and the corresponding labour. Shipping and transport costs are to be paid by the customer.

The warranty does not cover:

- repairs of malfunctions caused by natural disasters, mechanical shocks (falls, collisions, etc.), electrical system defects, negligence, misuse, maintenance or repairs carried out with non-original materials
- any other misuse or use not intended by the Manufacturer
- damage caused by service failings or inefficiencies due to causes or circumstances out of the Manufacturer's control

- wear and/or deterioration of parts due to normal use and parts that might break due to misuse or maintenance carried out by personnel not authorised by the Manufacturer.

To request maintenance interventions or obtain technical information about the device, contact an authorised Service Centre or the device Manufacturer directly.



The customer will not be refunded for damage caused by device downtime.

## 1.5 MANUFACTURER IDENTIFICATION

C.S.O. SRL

Costruzione Strumenti Oftalmici

Via degli Stagnacci, 12/E

50018 - Scandicci (FI) - ITALY

phone: +39-055-722191 - fax +39-055-721557

[cso@csoitalia.it](mailto:cso@csoitalia.it)

[www.csoitalia.it](http://www.csoitalia.it)

## 2 SAFETY

### 2.1 SAFETY WARNINGS

**DANGER**

Danger of electric shock. Do not let water fall on the device. Do not immerse the device in water or other liquids.

**DANGER**

Danger of electric shock. If the power supply cables are damaged, they must be replaced by an authorised Service Centre to prevent any risk.

**DANGER**

Danger of electric shock. Unplug the power supply cable from the power socket before disinfecting or cleaning the device and before any maintenance operation.

**DANGER**

Danger of electric shock. Do not touch the power supply cables with wet hands.

**DANGER**

Danger of electric shock. Do not allow the power supply cables to come into contact with sharp edges or cutting parts. Always fix the power supply cables in place with ties.

**CAUTION**

Do not use the device if visibly damaged. Periodically inspect the device and connection cables to check for signs of damage.

**CAUTION**

Always keep the device out of the reach of children.

**CAUTION**

Danger of falling device. Do not leave loose cables, as they might be of obstacle or danger for the patient or operator.

**CAUTION**

Danger of tripping and falling. Do not leave the power supply or connection cables loose in places where people may walk.

**CAUTION**

If you notice a strange odour or smoke coming out of the device or if it becomes hot, turn it off immediately. Do not continue to use a damaged device or damaged component. Danger of injuries.

**CAUTION**

The electric network must have a residual-current device ( $I\Delta n=30\text{mA}$ ) and circuit breaker ( $V_n=230\text{V}$ ) to protect the device. Place the device in such a way that the power socket is easily accessible.



It is forbidden to carry out technical operations on the device that are not indicated or described in these instructions for use.



It is forbidden to place the device in humid, dusty places or environments subject to sudden variations in temperature and humidity.



It is forbidden to use extension cables not authorised by the device Manufacturer.



It is forbidden to use the device outdoors.

## 2.2 DEVICE IDENTIFICATION

### 2.2.1 REGISTRATION DATA IN THE LIST OF MEDICAL DEVICES

The device registration data can be verified on this page of the website of the Ministry of Health:

[Ministero della Salute - Ricerca dispositivi](#)

### 2.2.2 DEVICE DATA PLATE

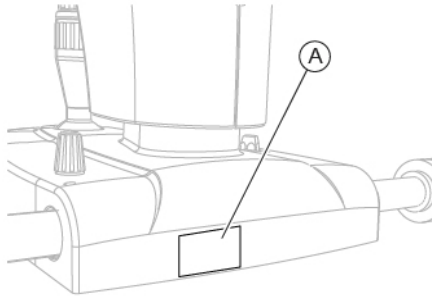
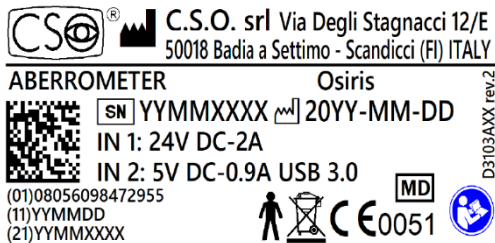



Fig. 1 - Data plate position



Pos	Description
A	Device data plate





**C.S.O. srl** Via Degli Stagnacci 12/E  
 50018 Badia a Settimo - Scandicci (FI) ITALY

---

**ABERROMETER** Osiris

SN YMMXXXX  20YY-MM-DD

IN 1: 24V DC-2A  
 IN 2: 5V DC-0.9A USB 3.0

(01)08056098472955  
 (11)YYMMDD  
 (21)YYMMXXXX

D3103AXX rev.2



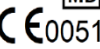





Fig. 2 - Device data plate

### 2.2.3 POWER SUPPLY UNIT DATA PLATE

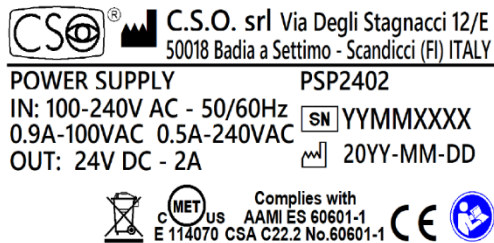

Fig. 3 - PSP2402 power supply unit data plate

## 2.3 INTENDED USE

Osiris is a medical device that allows the detection of total ocular aberrations in ophthalmic practice.

The device allows to evaluate wavefront quality and eye aberrations measurements thanks to a PWS (Pyramidal WaveFront Sensor) and to an advanced application software.

The information provided allows the accurate assessment of not only traditional defects but also more complex ocular aberrations.

The device can measure aberrations with a resolution of 45,000 points (at the maximum pupil diameter), with a wide dynamic, thanks to the use of a pyramidal sensor. This device is also able to measure the total wavefront in real time with a frame rate of up to 33 images per second: this makes it possible to measure all non-stationary phenomena such as changes in power and aberrations during the accommodation phases.

The device has no known contraindications.

The main features of the device are listed below.

### Aberrometry

Together with the application software, the device allows to perform analyses such as refractive error maps and visual simulations (PSF, MTF and convolution with eye chart), which help to understand and explain the patient's visual discomfort.

It is possible to combine the total aberrometry results with the corneal aberrometry results of other devices, it is possible to calculate the wavefront internal component and to evaluate the impact of a toric system on vision.

### **Dynamic accommodation**

During the evaluation of the accommodation phases, it is possible to measure the ocular wavefront in real time.

### **Densitometry**

The device allows to capture backlit images with no reflection. The data extracted from these images allow the objective diagnostic of the cataract and the evaluation of the opacity of the optical media.

### **Additional device features with the application software**

Together with the application software, the device allows for:

- Guided manual acquisition
- Management of patient data and the possibility of personalizing research and statistics
- Analysis of the patient's ocular wavefront under various refractive stimulus conditions, both as a deviation from the ideal wavefront and as a refractive difference from the ideal.
- Zernike analysis of the measured wavefront.
- Optical quality summary for assessing the effects of the measured aberrations on the wavefront.
- Comparisons and differences between aberration maps for follow-up evaluation.



The device must only be used by specialist practitioners and sector operators (such as optometrists), within the limits of the laws and regulations for the exercise of the profession.



Patient area: any volume in which a patient with applied parts may intentionally or unintentionally come into contact with other electromedical devices or electromedical systems, masses or foreign masses, or other people in contact with these elements.

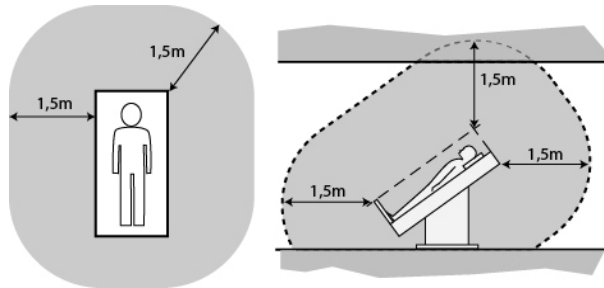

Fig. 4 - Patient area

## 2.4 MEDICAL DEVICE CLASSIFICATION

Technical data	Value
Classification based on annexe IX of Directive 93/42/EEC and subsequent modifications	Class IIa

## 2.5 ELECTROMEDICAL DEVICE CLASSIFICATION

Classification in compliance with technical specification IEC 60601-1

Technical data	Value
Type of protection against direct and indirect contacts	Class I
Applied parts	Type B
Degree of protection against humidity	IP20 (no protection against infiltration by liquids)
Sterilisation or disinfection method	This device can be disinfected
Degree of protection in the presence of anaesthetics or flammable detergents	No protection
Degree of electrical connection between device and patient	Devices with part applied to the patient
Use conditions	Continuous operation

## 2.6 ENVIRONMENTAL CONDITIONS

Phase	Technical data	Min	Max
Transport	Temperature	-40°C	+70°C
	Atmospheric pressure	500 hPa	1060 hPa
	Relative humidity	10%	95%
Storage	Temperature	-10°C	+55°C
	Atmospheric pressure	700 hPa	1060 hPa
	Relative humidity	10%	95%
Use	Temperature	+10°C	+35°C
	Atmospheric pressure	800 hPa	1060 hPa
	Relative humidity	30%	90%



### CAUTION

Danger of damage to the device. During transport and storage, the device may be exposed to the environmental conditions described, only if kept in the original package.

## 2.7 DISPOSAL AT THE END OF THE USEFUL LIFE



Instructions for the correct disposal of the device pursuant to European Directives 2012/19/EU and 2011/65/EU regarding the reduction of the use of dangerous substances in electrical and electronic equipment, as well as waste disposal.

At the end of its useful life, the device must not be disposed of with urban waste. The device may be delivered to designated separate collection centres set up by the municipal administration or to dealers that offer this service. Separately disposing of an electrical device prevents potential negative consequences for the environment and health caused by improper disposal and allows the materials it is made of to be recycled so as to attain significant savings in energy and resources. The data plate of the device displays the symbol of the crossed-out wheeled bin. The crossed-out wheeled bin symbol indicates the obligation to collect and dispose of electrical and electronic equipment separately at the end of their useful life.



The user must consider the potentially dangerous effects for the environment and human health arising from the improper disposal of the whole device or its parts.

Should the user wish to dispose of the device at the end of its useful life, the Manufacturer facilitates its potential reuse and recovery and the recycling of the materials contained therein. This prevents the release of hazardous substances into the environment and promotes the conservation of natural resources. Before disposing of the device, it is crucial to take into consideration European and national regulations, which prescribe the following:

- not to dispose of it as urban waste, but separate its parts, seeking advice from a firm specialised in the disposal of electrical/electronic equipment or the local administration in charge of waste collection.

- in the event that a new device is purchased from the same Manufacturer to replace an old one placed on the market before 13 August 2005, equivalent and with the same functions as the new device, the Distributor or Manufacturer is legally required to collect the old device.
- if the user decides to dispose of a used device placed on the market after 13 August 2005, the Distributor or Manufacturer is legally required to collect it.
- the Manufacturer takes care, by joining the appropriate technological waste disposal consortium, of the treatment and recycling of the used device collected, bearing any costs.



The Manufacturer is available to provide the user with information regarding the dangerous substances contained in the device, the recycling of these substances and the potential reuse of the used device.

Strict administrative sanctions for those failing to comply are provided for by law.

For specific information about disposal in countries other than Italy, contact your local Dealer.

## 2.8 MANUFACTURER DECLARATIONS

### 2.8.1 ELECTROMAGNETIC COMPATIBILITY

The device is subject to specific requirements regarding electromagnetic compatibility (EMC). The following factors may cause electromagnetic interference:

- Portable and mobile radio frequency (RF) communication devices located in the vicinity of the device.
- Other products installed near or connected to the device.
- Accessories, cables and spare parts not specified in the instructions for use and not sold by CSO as spare parts.

When using the device, certain precautions must be taken to respect EMC, including:

- Observe the instructions for use.
- Follow the restrictions and instructions in this section.

#### Restrictions on essential performance

The device provides the following essential performance: accuracy of measurement. If the acquisition is damaged due to electromagnetic interference, the image will not meet the quality threshold and the application software will warn the user with a message.

#### Danger from electromagnetic radiation



#### CAUTION

Using the device in the vicinity of other devices or connected to other devices not described in the instructions for use (e.g. in combination with an ophthalmic table) may cause interference with the functioning of the device.

Should it be necessary to use the device with other devices not described in the instructions for use, all devices must be monitored to ensure correct functioning.

**CAUTION**

Do not use portable high-frequency (HF) communication equipment (such as antenna cable and external antennas) and do not place equipment cables within a 30 cm (12 inches) radius around the device. Otherwise, a deterioration in the performance of the device can be expected.

**CAUTION**

The use of accessories, transducers and cables other than those specified or supplied by the manufacturer of this equipment could lead to increased electromagnetic emissions or decreased electromagnetic immunity of this equipment and result in improper operation.

**CAUTION**

Portable radio frequency (RF) communication equipment (including peripherals such as antenna cables and external antennas) must be used at a distance of no less than 30 cm (12 inches) from any part of the device, including cables specified by the manufacturer. Otherwise, degradation of the performance of this equipment may occur.

**Environmental conditions for intended use**

The device is intended for use in professional healthcare facilities as regards electromagnetic compatibility. These are in particular hospitals and doctors' surgeries, including those connected to the public electricity network (e.g. in residential areas), and opticians' and optometrists' premises.

The device is not intended for operation in the following environments:

- Home healthcare (e.g. residential accommodation, nursing homes)
- Outdoor environments
- In vehicles (for example, cars, trains, ships, planes)
- Other special environments (for example military facilities, heavy industry, medical treatment or diagnostic facilities with high-powered devices. These include in particular high-frequency surgical devices, short-wave therapy equipment and magnetic resonance devices)

The device is designed to be used in a room with the following electromagnetic characteristics:

<b>Emission test</b>	<b>Compliance</b>	<b>Electromagnetic environment</b>
<b>Radio frequency emission. CISPR 11</b>	Assembly 1	The device uses radio frequency energy only for its internal functioning. The device's electromagnetic emissions are very low and should not cause interference with nearby electronic devices.
<b>Radio frequency emission. CISPR 11</b>	Class B	The device may be used in all environments, including domestic ones. The device can be connected directly to a low-voltage electric network like that of residential buildings.
<b>Harmonic emissions. IEC 61000-3-2</b>	Class A	The device may be used in all environments, including domestic ones. The device can be connected directly to a low-voltage electric network like that of residential buildings.
<b>Limitation of voltage changes, voltage fluctuations and flicker. IEC 61000-3-3</b>	Compliant	The device may be used in all environments, including domestic ones. The device can be connected directly to a low-voltage electric network like that of residential buildings.

Immunity test	IEC 60601-1-2 test level	Compliance level	Electromagnetic environment
<b>Electrostatic discharge.</b> <b>IEC 61000-4-2</b>	±6 kV in contact. ±8 kV in air	±6 kV in contact. ±8 kV in air	The floors must be made of wood, concrete or ceramic tile. If the floors are covered with synthetic material, the relative humidity must be at least 30%.
<b>Temporary/rapid sequences of electrical pulses.</b> <b>IEC 61000-4-4</b>	±2 kV for power supply lines. ±1 kV for input/output lines	±2 kV for power supply lines. Not applicable	The mains power supply must be that of a typical commercial or hospital environment.
<b>Impulse.</b> <b>IEC 61000-4-5</b>	±1 kV differential mode. ±2 kV common mode	±1 kV differential mode. ±2 kV common mode	The mains power supply must be that of a typical commercial or hospital environment.
<b>Voltage dips. Brief disruptions and variations in voltage on power supply input lines.</b> <b>IEC 61000-4-11</b>	<5% Un for 0.5 cycles. 40% Un for 5 cycles. 70% Un for 25 cycles. <5% Un for 5 s	<5% Un for 0.5 cycles. 40% Un for 5 cycles. 70% Un for 25 cycles. <5% Un for 5 s	The mains power supply must be that of a typical commercial or hospital environment. If the device user requires continued operation during power outages and voltage dips, the device must be powered by an uninterrupted power supply or battery.
<b>Magnetic field at mains frequency (50/60Hz).</b> <b>IEC 61000-4-8</b>	3 A/m	3 A/m	The magnetic fields at mains frequency must have the same levels as a typical commercial or hospital environment.

Immunity test	IEC 60601-1-2 test level	Compliance level	Electromagnetic environment
RF conducted IEC 61000-4-6	3 Vrms from 150kHz to 80 MHz	3 Vrms	(1)
RF radiated IEC 61000-4-3	3 V/m From 80 MHz to 2.5 GHz	3 V/m	

(1) Portable and mobile RF communication equipment must be used no closer to any part of the device, including cables, than the recommended separation distance (d) calculated from the equation applicable to the frequency of the transmitter.

$$d=1.167*\sqrt{P}$$

$$d=1.167*\sqrt{P} \text{ 80 MHz to 800 MHz}$$

$$d=2.333*\sqrt{P} \text{ 800 MHz to 2.5 GHz}$$

P: maximum output power rating of the transmitter in watts (W), according to the transmitter Manufacturer.

d: recommended distance in metres (m) at which portable radio frequency (RF) devices can be used.

The field strength emitted by fixed RF transmitters, as determined by an electromagnetic site survey, must be less than the compliance level in each frequency range. Interference may occur in the vicinity of



equipment marked with the following symbol:



(Un) is the AC mains voltage prior to application of the test level.

At 80 MHz and 800 MHz, the higher frequency range applies. The exposed electromagnetic environment may not apply in all situations. Electromagnetic propagation is affected by absorption and reflection from structures, objects and people.

### 3 DEVICE DESCRIPTION

#### 3.1 SUPPLY DESCRIPTION

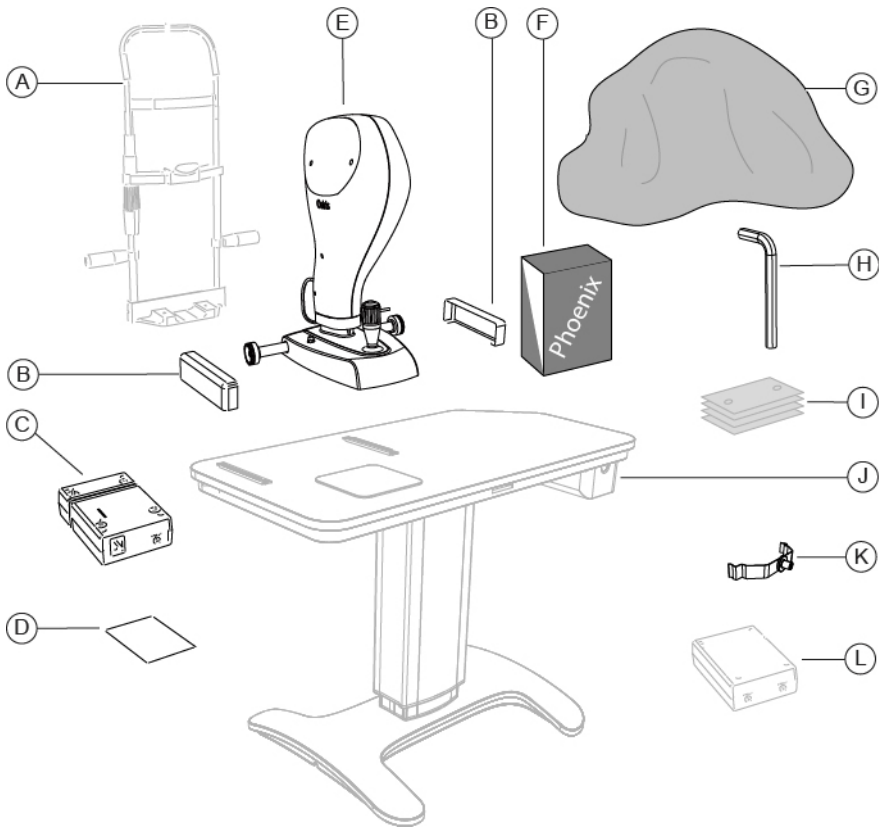

Fig. 5 - Supply description



Optional: accessory not provided with the basic supply.  
Accessories marked with (\*) are essential for the proper functioning of the device.



For the list of accessories and available models, contact the Manufacturer or local Distributor.

Pos	Name		Description
A	Chin rest with adjustable chin cup	Optional (*)	Adjustable height. Adjustable distance between chin and forehead. Adjustable chin cup.
B	Wheel cover		Protection against accidental crushing of fingers.
C	Power supply unit		A cable is provided with the power supply unit.
D	Sticker pad	Optional	Sticker for right/left identification.
E	Osiris device		Consisting of an image acquisition unit, a USB cable for connection to the PC and a connector on the base for connection to the power supply unit.
F	Application software		Application software for image acquisition and device management.
G	Dust cover	Optional	Place on the device when not in use to protect it from dust.
H	Hexagon wrench with screws	Optional	
I	Package of chin cup papers		
J	Ophthalmic table	Optional	Table top with one or two columns and electronic adjustment of height. Drawer and auxiliary sockets with cable guide.
K	Calibration testing tool		Tool with reference value for calibration check
L	Isolation transformer	Optional	230V/230V for the use of non-electromedical devices in the patient area.

**3.1.1 OSIRIS DEVICE**

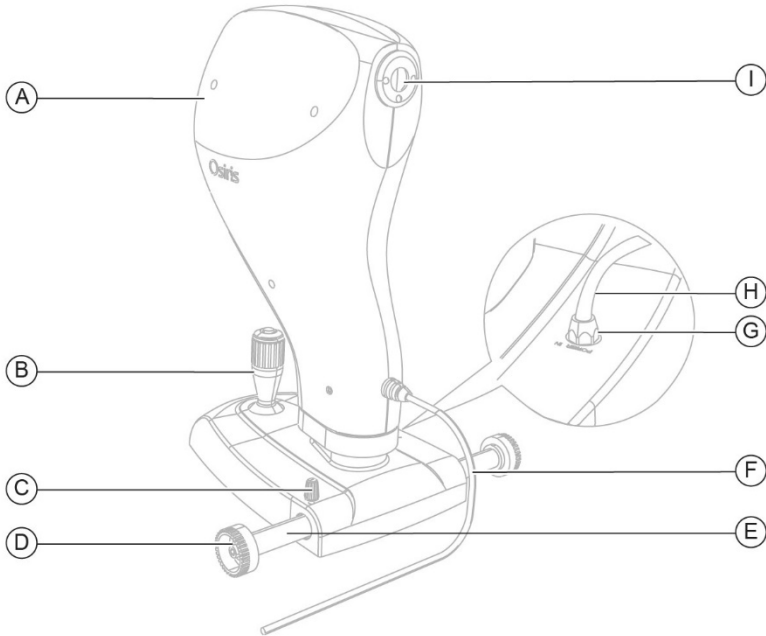

Fig 6 - Osiris device

Pos	Description
A	Osiris device
B	Joystick
C	Device locking knob
D	Cogwheels
E	Sliding rod
F	USB connection cable between device and PC
G	Connector
H	Device power supply cable
I	Shooting channel

### 3.1.2 POWER SUPPLY UNIT

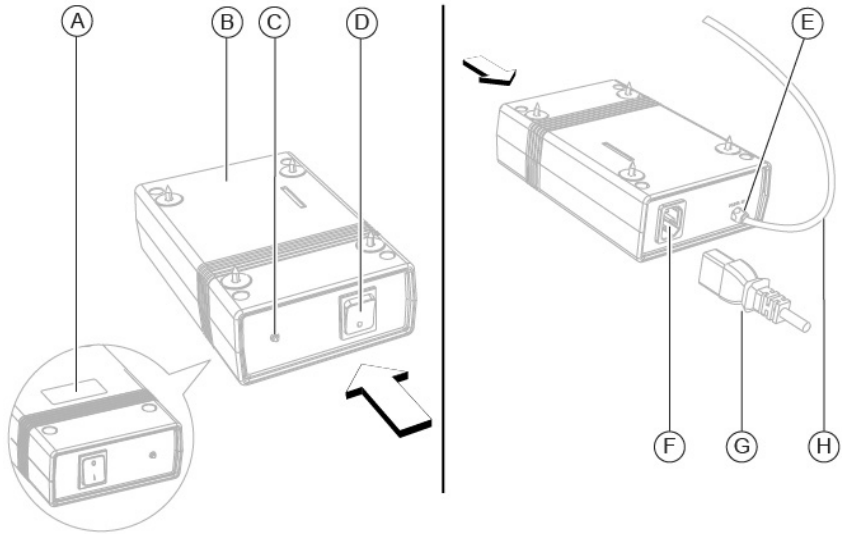

Fig. 7 - Power supply unit

Pos	Description
A	Data plate
B	Power supply unit
C	Power supply status control light
D	ON/OFF switch
E	Device out connector
F	Power grid connector
G	Power supply cable from electric network
H	Device power supply cable

**3.1.3 CHIN REST**

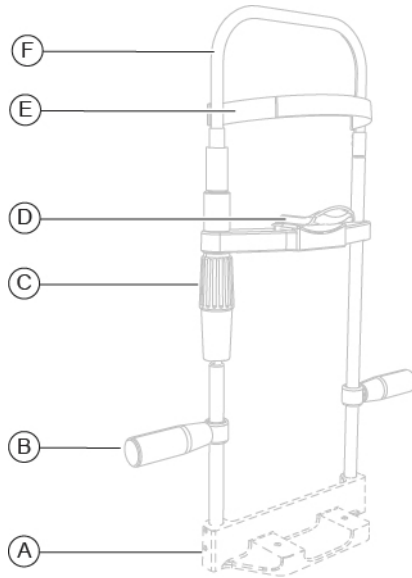

Fig. 8 - Chin rest

Pos	Description
A	Chin rest support (*)
B	Handle
C	Chin cup adjustment knob
D	Adjustable chin cup
E	Forehead rest
F	Chin rest structure



(\*) The chin rest support may vary depending on the table top where the chin rest will be installed.

### 3.1.4 OPHTHALMIC TABLE

Different table models are available based on the customer's choice. The table is composed of a table top on which the cogged wheels for the device compartment are installed. The table has one or two motorised telescopic columns that permit the height adjustment of the table top.



Fig 9 - One-column table



Read the instructions for use of the ophthalmic table.

### 3.1.5 PERSONAL COMPUTER

The device must be used in combination with a PC.

Minimum system requirements:

- CPU: i5 quad core (2,5 GHz)
- RAM: 8 GB
- Video Card: 1 GB RAM (not-shared) resolution 1920 x 1080 pixels
- Operating system: Windows 11 (64 bit)



Fig. 10 - Personal Computer



The PC must comply with Directive IEC 62368-1 Information technology equipment - Safety - Part 1: General requirements.

If the PC is installed in the patient area, it is also necessary to install an isolation transformer compliant with Directive IEC 60601-1 - "Medical electrical equipment - Part 1: General requirements for basic safety and essential performance".

It is possible to connect other accessories to the PC (printer, modem, scanner, etc.) through the analogue or digital interfaces.

The accessories (printer, modem, scanner, etc.) must be installed outside the patient area.



The accessories must comply with Directive IEC 62368-1 Information technology equipment - Safety - Part 1: General requirements.

If the accessories are installed in the patient area, it is also necessary to install an isolation transformer compliant with Directive IEC 60601-1 - "Medical electrical equipment - Part 1: General requirements for basic safety and essential performance".

### 3.2 TECHNICAL DATA

Technical data	Value
Data transfer	USB 3.0
Power supply	External power supply unit 24 VCC In: 100-240 VAC - 50/60 Hz - 0.9-0.5 A Out: 24 VDC 2 A
Network cable	with C14 socket
Dimensions (Height x Length x Depth)	425 x 315 x 265 mm
Weight	5.8 kg
Chin rest stroke	70 mm ±1
Minimum height of the chin cup from the work surface	24 cm
Base movement (x, y, z)	105 x 110 x 30 mm
Working distance	78 millimetres

#### Light sources

Technical data	Value
Aberrometer	LED@850 nm
Auxiliary	LED @780 nm
Fixation	LED @450-650 nm

#### Aberrometry

Technical data	Value
Points measured at maximum pupil	45000
Spatial resolution	41 µm
Pupillary range	2-9 mm
Dioptric range	Sph from -15 D to +15 D Cyl ±10 D
Repeatability	0.05 D on test eyes

## 4 DEVICE USE

### 4.1 HOW TO INSTALL THE DEVICE



#### CAUTION

**Danger of falling device. The table must be installed on a horizontal and stable surface.**

- 1 Place the ophthalmic table in the room. The table must be lifted by two people.
- 2 If present, lock the table wheels. Lower the brake lever.
- 3 Place the power supply unit under the table top. Screw the screws into the four holes.

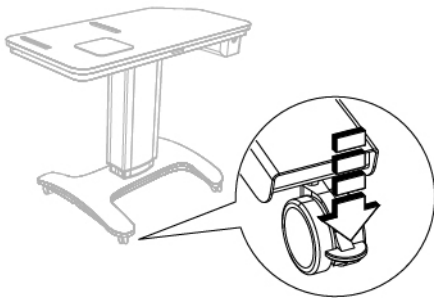

Fig. 11 - Table placement

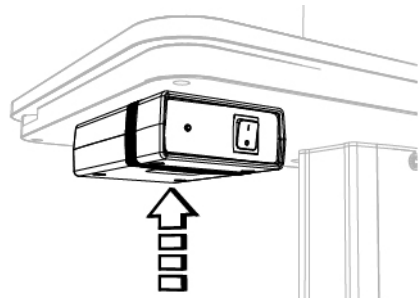

Fig. 12 - Power supply unit placement

- 4 Check the position of the sticker with respect to the central axis (A).
- 5 Remove the protective film. Place the sticker pad between the two cogged wheels and the sliding plate.



While placing the sticker pad (sticker for right/left identification) on the table top, observe the specified distances.

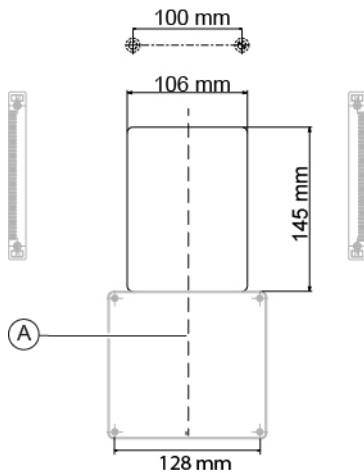

Fig. 13 – Distances

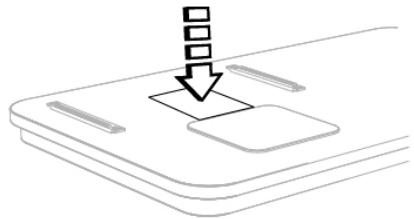

Fig. 14 – Placement of the sticker pad

- 6 Remove the joystick protection (B) under the device base.

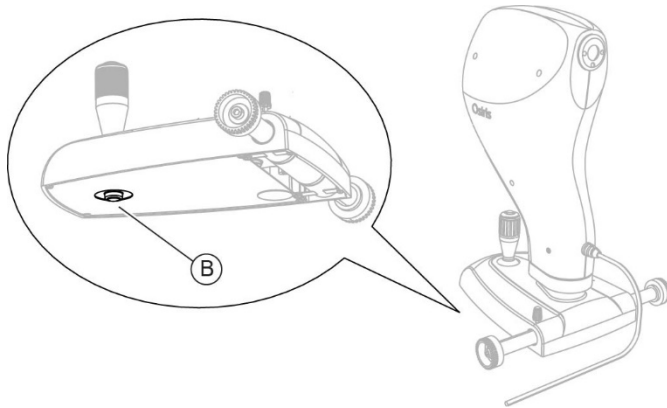

Fig. 15 – Protection removal

- 7 Place the device on the table top and correctly align the cogwheels on the cogged guides.
- 8 Fasten the two wheel covers to the cogged guides on the table top.

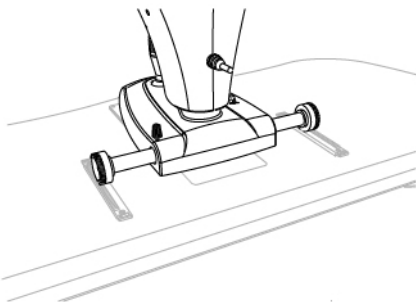

Fig. 16 - Placement of the device

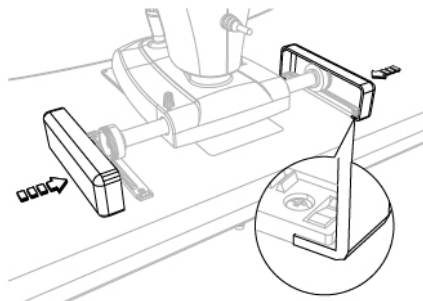

Fig. 17 - Placement of wheel covers

- 9 Install the chin rest. Beneath the table top, there are two screws to fasten the chin rest to the table top.



The chin rest must be installed so that the eye-level indicator (1) is placed at a height of 380 mm from the table top.

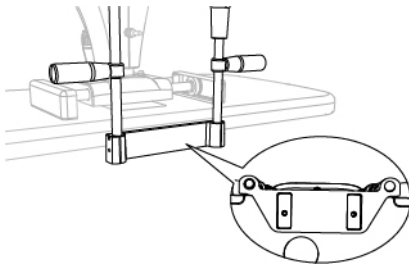

Fig. 18 - Placement of the chin rest

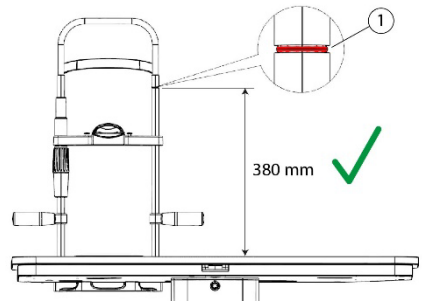

Fig. 19 – Correct height of the eye-level indicator

- 10 If the eye-level indicator does not reach the required height, adjust the chin rest.
- 11 Loosen the 4 locking grub screws placed on the chin rest support.
- 12 Slide the chin rest rods until the required height of 380 mm is reached. Tighten the previously loosened locking grub screws.



The chin rest rods must be adjusted upwards by no more than 15 mm.

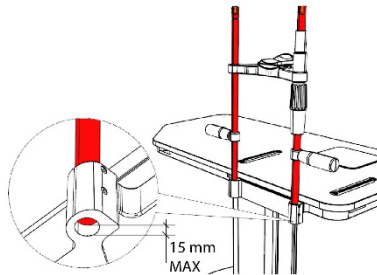
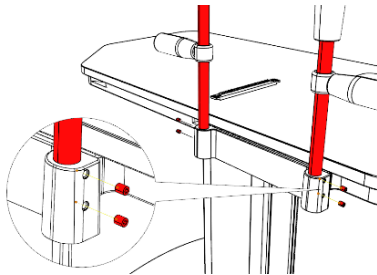

Fig. 20 – Loosening the chin rest grub screws    Fig. 21 – Maximum rod adjustment height

- 13 Complete the electrical connections between the different components.

## 4.2 HOW TO CONNECT THE DEVICE

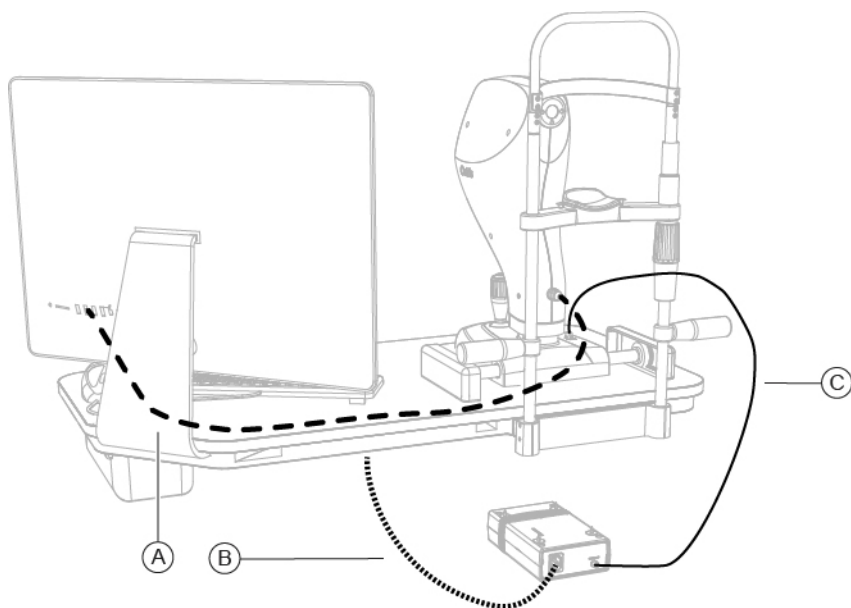

Fig. 22 - Device connection

Pos	Name
A	USB connection cable between device and PC
B	Power supply cable to connect the electric table to the power supply unit
C	Power supply cable for the connection of the power supply unit to the device



To connect the table base to the electric network, read the instructions for use of the table or ophthalmic unit.

### 4.3 HOW TO ARRANGE THE ELECTRIC CABLES

**CAUTION**

Danger of falling device. Do not leave loose cables, as they might be of obstacle or danger for the patient or operator.

**CAUTION**

Danger of tripping and falling. Do not leave the power supply or connection cables loose in places where people may walk.

**DANGER**

Danger of electric shock. Do not allow the power supply cables to come into contact with sharp edges or cutting parts. Always fix the power supply cables in place with ties.



It is forbidden to use extension cables not authorised by the device Manufacturer.



For the proper placement of the electric cables and the connection to the lifting column, read the instructions for use of the ophthalmic tables or ophthalmic units. The instruction manual can also be downloaded from the website [www.csoitalia.it](http://www.csoitalia.it).



The power socket on the lower part of the column of the ophthalmic table is used to connect to the electric network. One of the power sockets at the top of the lifting column is dedicated to the power supply unit of the device.

## 4.4 HOW TO TURN ON THE DEVICE



Before using the device, read the instructions in the Phoenix application software handbook.

- 1 Turn on the PC.
- 2 Switch the power switch of the power supply unit to turn it ON.
- 3 Start the Phoenix application software.
- 4 Wait until the main screen of the application software is displayed.
- 5 When using the device for the first time or after a long period of non-use, calibration should be tested. Follow the instructions given in paragraph **“How to test the calibration”** on page. 39.

### 4.4.1 HOW TO TEST THE CALIBRATION

- 1 Make sure the calibration testing tool is clean and undamaged. If needed, clean it using a soft cloth.



Do not use solvents or thinners to clean the calibration testing tool.

- 2 Position the calibration testing tool on the chin rest.
- 3 Start the acquisition of a new examination.
- 4 Press CTRL+T. "Test Eye" will be displayed on screen.
- 5 Make sure the sphere is aligned and properly focused in relation to the shooting channel.

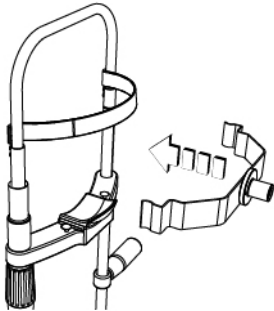

Fig. 23 - Positioning of the calibration testing tool

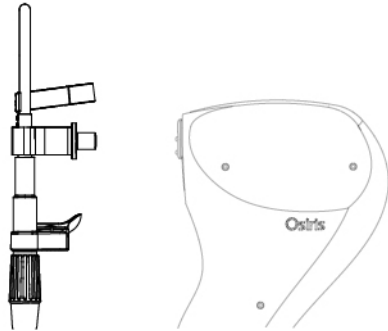

Fig. 24 - Alignment of the calibration testing tool with the device

- 6 Press the joystick button to perform an acquisition.
- 7 Check whether the measured value for a diameter of 4 mm@12.5 mm corresponds to the benchmark value.

**The benchmark value is specified on the back of the calibration check tool. The measured value must correspond to the benchmark value, equal to  $\pm 0.125 D$ .**

- 8 If the measurements are not considered reliable, repeat the procedure.

#### 4.4.2 HOW TO CREATE A NEW PATIENT

- 1 Click NEW PATIENT and enter their personal data. If the patient is already present in the database, you can automatically search for their surname by typing it into the command prompt.
- 2 A new examination will be created automatically.
- 3 Select the examination to be performed.
- 4 The image acquisition screen will open. Now it will be possible to proceed with the image acquisition.

#### 4.4.3 HOW TO CREATE A NEW EXAMINATION

- 1 Click NEW EXAMINATION.
- 2 Select the examination to be performed.
- 3 The image acquisition screen will open. Now it will be possible to proceed with the image acquisition.

#### 4.5 HOW TO ADJUST THE CHIN CUP

- 1 Ask the patient to sit down.
- 2 Move the chin cup left or right. The chosen position will determine the position of the eye to be examined.

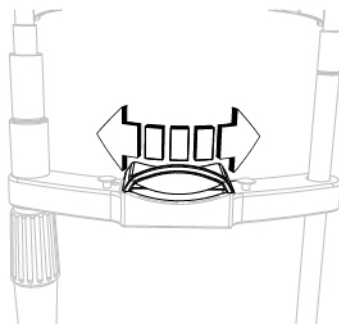

Fig. 25 - Chin cup positioning

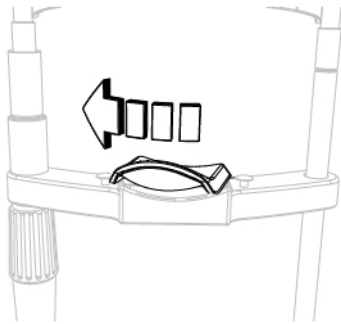

Fig. 26 – Chin cup positioning for left eye

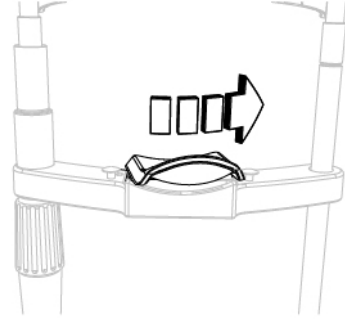

Fig. 27 – Chin cup positioning for right eye

- 3 Show the patient how to position their face against the chin cup and forehead rest
- 4 Check that the eye is correctly positioned in relation to the shooting channel.

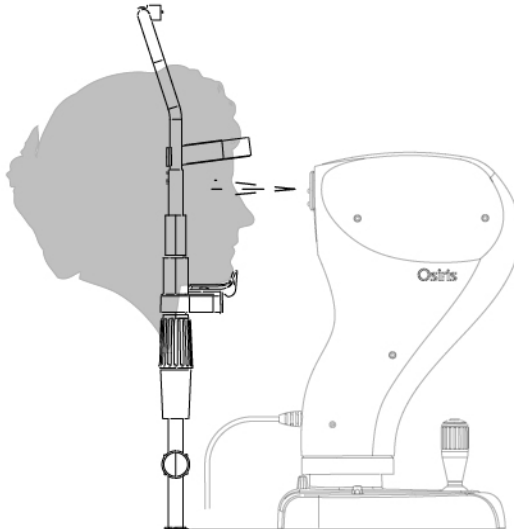

Fig. 28 - Patient position on the chin rest

- 5 Raise or lower the chin cup by rotating the knob.
- 6 Begin acquiring images as directed in section **“How to acquire an image” on page 44.**

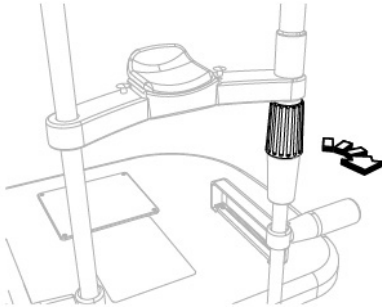

Fig. 29 - Knob rotation

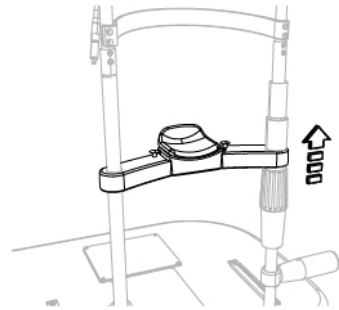

Fig. 30 - Chin cup placement

- 7 At the end of the acquisition procedure, ask the patient to lift their face from the chin cup and forehead rest.
- 8 Move the chin cup in the opposite direction to that chosen before.
- 9 Show the patient how to position their face against the chin cup and forehead rest
- 10 Check that the eye to be examined is correctly positioned in relation to the shooting channel.
- 11 Begin acquiring images as directed in section **“How to acquire an image” on page 44.**

## 4.6 HOW TO ACQUIRE AN IMAGE

- 1 Rotate the joystick and align the device with the patient's eye.
- 2 Move the device towards the eye. Keep the reflection of the corneal vertex centred.
- 3 Perform small movements with the joystick to obtain the best image alignment.

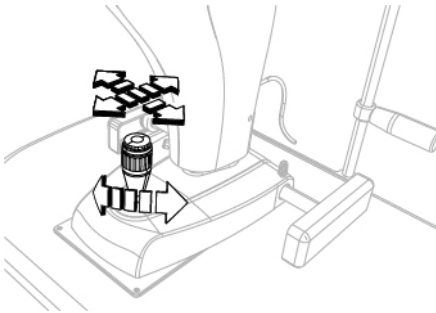

Fig. 31 - Placement of the device

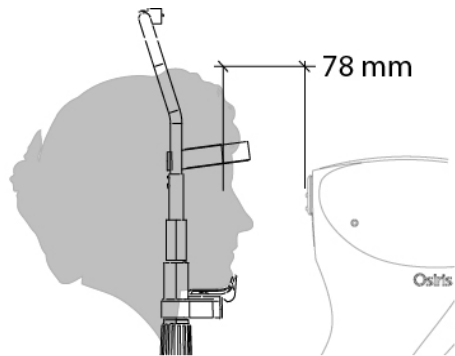

Fig. 32 - Distance from the patient

- 4 Press the joystick button to acquire the image. Press the joystick button to stop the acquisition. The image will be saved in the gallery.
- 5 Double click the acquired image to process it and display the result on the computer screen.

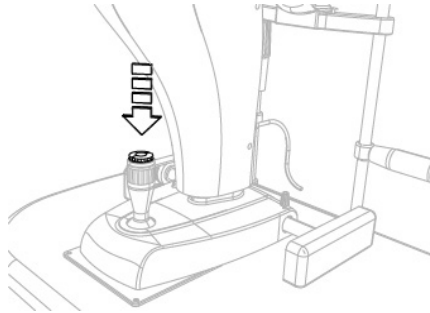

Fig. 33 - Image acquisition



Refer to the application software handbook for the management of the image in the database.

#### 4.7 HOW TO REPLACE CHIN CUP PAPERS



At the end of each examination, always remove the chin cup paper, so that there is always a new sheet, to ensure hygiene for the next patient.

This device is provided with a package of chin cup papers. After using the last chin cup paper, replace the pack.

- 1 Extract the two plastic rivets
- 2 Position the new pack of chin cup papers
- 3 Replace the plastic rivets in the holes of the pack and in the holes of the chin cup.

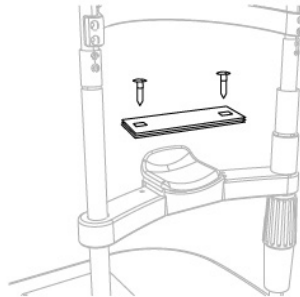

Fig. 34 - Changing the chin cup papers



To order the spare part, see the part number in the **“List of spare parts and accessories” on page 53.**

## 4.8 HOW TO TURN OFF THE DEVICE



### CAUTION

Do not turn off the computer and do not disconnect the connection cable between the computer and the device when the program is in use.

- 1 Lock the device. Turn the locking knob.
- 2 Exit the Phoenix application software. Turn off the computer.
- 3 Press the power switch of the power supply unit to turn it OFF.
- 4 Place the dust cover on the device to prevent dust accumulation.

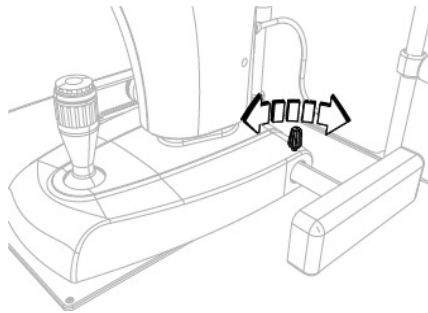

Fig. 35 - Locking the device

## 5 ORDINARY MAINTENANCE

### 5.1 SAFETY WARNINGS



#### DANGER

Danger of electric shock. Unplug the power supply cable from the power socket before disinfecting or cleaning the device and before any maintenance operation.



#### CAUTION

The device does not contain any parts requiring user intervention. Do not remove any parts of the device.



It is forbidden to carry out any maintenance operation on the device not indicated in the instructions for use.



In the case of damage or malfunction or for any maintenance operations not indicated in the instructions for use, contact an authorised Service Centre or the device Manufacturer.

### 5.2 ELECTRICAL SAFETY CHECK



#### DANGER

Electrical danger due to age and wear.

The electrical safety of the device may decrease with age and wear. Follow and comply with the regulations in force in the country of use regarding electrical tests on devices.

Otherwise, have an electrical safety test performed at least once a year in accordance with IEC 62353 by the manufacturer or a qualified technician. Follow the procedure indicated in the technical manual issued by the manufacturer.

Record and keep evidence of the tests and measurements taken during tests.

The test ends with a device operation test. This operation must be performed by a person familiar with the device application.

### 5.3 CLEANING AND DISINFECTION

**CAUTION**

Carefully follow the instructions for cleaning and disinfection described in this manual, in order to avoid any damage to the device and accessories.

**CAUTION**

A correct cleaning and disinfection procedure, together with appropriate operating procedures, is essential to preventing the spread of infections or cross contamination.

**CAUTION**

**Danger of material damage. Do not use spray products. Do not use excessively wet cloths, as they may drip. If needed, use a damp and well wrung out cloth. Make sure no liquid penetrates into the device.**



Cleaning and disinfection procedures must be carried out regularly.



Device parts that do not come into direct contact with the patient must be cleaned at least once a day.

Device parts that do come into direct contact with the patient must be thoroughly cleaned and disinfected after each use.

This section describes the procedures to be carried out during use and maintenance in order to ensure proper cleaning and disinfection of the device and its accessories.

### 5.3.1 RECOMMENDED PRODUCTS FOR CLEANING AND DISINFECTION



#### CAUTION

**Danger of material damage. Do not use solvents, acidic or basic solutions (pH <4,5 or >8,0), abrasive or caustic substances, chlorine-based and chlorine-derived products.**

**The Manufacturer is not liable for any damage caused by using disinfectant products not indicated in this manual.**

The choice of the most suitable product and procedures for the cleaning and disinfection of the device must take into account both the sensitivity of the device to specific substances and the effectiveness of the product.

For the cleaning and disinfection procedures, use products approved by the FDA or EC for medical devices or medical-surgical devices.

Use the products as listed below, divided by category:

Detergents	Use polyenzymatic solutions or neutral surfactant-based solutions.
Disinfectants and decontaminating products	Use products for disinfecting surfaces (containing or not containing aldehyde) or formaldehyde-free surface disinfectants (i.e. Kohrsolin FF). Alternatively, you may use ethyl alcohol, 70% v/v alcohol or isopropyl alcohol.

For information about the use of the chosen product, follow the instructions provided by the manufacturer.

### 5.3.2 CLASSIFICATION OF THE CRITICALITY OF THE DEVICE



#### CAUTION

**The device supplied is not sterile and must not be sterilised prior to use.**

This device is classified as "non-critical" since it is only used on intact skin and therefore has a low infectious risk.

For devices classified as non-critical, regular cleaning or low-level disinfection is sufficient.

However, when the patient's condition is transmissible by direct contact or in case of accidental exposure to body fluids, the device must be disinfected with a higher-level disinfectant after cleaning.

### 5.3.3 DEVICE CLEANING



#### CAUTION

**Carefully follow the cleaning instructions described in this section in order to avoid damage to the device and its accessories.**



#### CAUTION

**Danger of material damage. Clean using a non-abrasive cloth to avoid damaging the surface.**



The device must be regularly cleaned.



The device is provided with a cover for protection from dust, especially during periods of non-use.

Clean the outer parts of the device using a damp, non-abrasive cloth and a rinse-free cleaning solution.



For more information about suitable cleaning products, read paragraph **"Recommended products for cleaning and disinfection"** on page 50.

#### 5.3.4 CLEANING THE APPLIED PARTS



##### CAUTION

**Danger of material damage. Only use detergent and disinfectant products specifically approved for medical devices or medical-surgical devices.**



The applied parts that come into direct contact with the patient during the examination must be thoroughly cleaned after each use with a disinfectant approved for the purpose.

- 1 Turn off the device and unplug it from the power socket.
- 2 Clean the applied parts using products suitable for surface disinfection (they may contain aldehyde).  
Alternatively, use a non-abrasive cloth soaked in a solution of water, ethyl alcohol (70% maximum) or isopropyl alcohol.



For more information about suitable cleaning products, read paragraph **“Recommended products for cleaning and disinfection”** on page 50.

#### 5.3.5 CLEANING THE OPTICAL COMPONENTS



##### CAUTION

**Danger of material damage. The device is equipped with optical components. The optical components of the device are precision and pressure-sensitive parts. Clean using a non-abrasive cloth to avoid damaging the surface.**

Clean the optical components carefully using a dry, non-abrasive, lint-free cloth.

#### 5.4 DEVICE EXCURSION CHECK

Check that the base sliding rod is well cleaned. Move the device base all the way to the right and all the way to the left, back and forth. Check that the device performs all movements completely.

## 5.5 DEVICE CALIBRATION TEST

Check the calibration to obtain accurate measurements. Check the calibration as indicated in paragraph “**How to test the calibration**” on page 39.

## 5.6 LIST OF SPARE PARTS AND ACCESSORIES

Code	Description
30010071D3F	Power supply cable
10101300	Isolation transformer 230V/230V. 800 VA (maximum load) power supply cable
4014020	Chin cup paper pack (50 pieces)
4013090	Dust cover
10070524	Table top 45x90 mm
10070144	Electric support with one column for table top (230 V, 50 Hz)
33071095	Power supply cable for electric support (95 cm)
103103900	PSP2402 input 100-240 V AC 50/60 Hz max 0.9 A output 24 VDC 2 A
300409135	Power supply cable 1.5 m
300409136	Power supply cable 5 m
103103201	Calibration check tool for aberrometer
100130700	Chin rest with adjustable chin cup
960130701	Adjustable chin cup
3020150	USB 3.0 cable 5 m



For spare parts or accessories not included in the list, ask the Manufacturer or local Dealer.

## 5.7 TROUBLESHOOTING

Issue	Cause	Solution	Note
<b>The device does not switch ON</b>	Power cable not connected to the power supply unit.	Connect the power supply cable of the device to the power supply unit. Press the ON button of the device.	If the device is powered through the table, check the connection of the table to the electric network. Check the operation of the table fuses.
<b>The PC does not start</b>	Power cable not connected to the power supply unit.	Connect the power supply cable to the power supply unit. Press the button of the power supply unit to turn it ON. Replace the PC.	Ensure that the electric system of the room is working correctly.
<b>The operating system of the PC does not start</b>	Hard Disk failure. Corrupted operating system.	Replace the Hard Disk. Reinstall the operating system. Replace the PC.	Ensure that the new PC meets to the minimum requirements of the device.

Issue	Cause	Solution	Note
<b>The Phoenix application software does not start</b>	<p>Hard Disk failure. The anti-virus software is preventing the start of the Phoenix application software. Corrupted operating system. The Phoenix application software does not work properly.</p>	<p>Replace the Hard Disk. Check the anti-virus software settings. Reinstall the operating system. Reinstall the Phoenix application software.</p>	<p>Contact Technical Assistance. The installation of the Phoenix application software requires administrator privileges.</p>
<b>The Phoenix application software does not work properly</b>	<p>The connection cable between the device and PC does not work properly. The anti-virus software interferes with the drivers of the Phoenix application software. The Phoenix application software is installed as local user.</p>	<p>Unplug and then re-plug the connection cable between the device and the PC. Replace the connection cable between the device and the PC. Uninstall the anti-virus software. Reinstall the Phoenix application software.</p>	<p>The installation of the Phoenix application software requires administrator privileges.</p>

Issue	Cause	Solution	Note
<b>The PC mouse does not work</b>	<p>Connection cable with the PC disconnected.</p> <p>The power switch of the mouse is OFF.</p> <p>The mouse batteries are exhausted (only for wireless mouse).</p>	<p>Check that the mouse connection cable is properly inserted into the USB port.</p> <p>Turn on the mouse by switching the power switch to ON.</p> <p>Replace the mouse batteries (only for wireless mouse).</p>	<p>Check whether there are any device conflicts in the PC control panel.</p>
<b>The PC keyboard does not work</b>	<p>Connection cable with the PC disconnected.</p> <p>The power switch of the keyboard is switched to OFF.</p> <p>The keyboard batteries are exhausted (only for wireless keyboard).</p>	<p>Check that the keyboard connection cable is properly inserted into the USB port.</p> <p>Turn on the keyboard by switching the power switch to ON.</p> <p>Replace the keyboard batteries (only for wireless keyboard).</p>	<p>Check whether there are any device conflicts in the PC control panel.</p>

Issue	Cause	Solution	Note
<p><b>The images can't be saved in the database</b></p>	<p>The database is not connected to the Phoenix application software. No network connection. The USB cable is faulty.</p>	<p>Check that the correct path to the "phoenix.mdb" file is specified on the database setup screen. Refresh the connection to the database file. Check that the network connection is working. Replace the USB cable.</p>	<p>Regularly check the connection to the data network.</p>
<p><b>Failed image acquisition</b></p>	<p>The patient moved or closed their eyes during the acquisition.</p>	<p>Ask the patient to keep their eyes open, look at the fixation light and not move their eyes.</p>	
<p><b>Failed image focusing</b></p>	<p>Presence of dust or grease on the optical parts of the device.</p>	<p>Clean the optical parts of the device with a soft cloth.</p>	<p>Make sure the patient does not touch the optical parts.</p>
<p><b>Failed recognition of the left/right part of the eye by the device</b></p>	<p>The black sticker has not been affixed to the device base. The position detector does not work.</p>	<p>Affix the black sticker to the device base.</p>	<p>Some colours and materials of the table top do not reflect the infrared light. Move a white paper below the device base to check the operation of the position detector.</p>

Issue	Cause	Solution	Note
<b>Device movement difficulties (forward, back, left, right)</b>	The joystick's plastic protection was not removed from the base during installation. The device locking knob is tight. The sliding rod is dirty.	Remove the joystick's plastic protection from the base. Loosen the device locking knob. Clean the sliding rod.	Before beginning the examination, check that the device locking knob is loosened.





COSTRUZIONE STRUMENTI OFTALMICI

Via degli Stagnacci 12/E | 50018 Scandicci (FI) | ITALY  
Phone: +39 055 722191 | Fax: +39 055 721557

[cso@csoitalia.it](mailto:cso@csoitalia.it) | [www.csoitalia.it](http://www.csoitalia.it)

OSIRISIFUENGCSO0207052025